

MINISTRY OF EDUCATION AND SCIENCE OF UKRAINE
NATIONAL TECHNICAL UNIVERSITY
"KHARKIV POLYTECHNIC INSTITUTE"



«ENTREPRENEURSHIP, TRADE AND EXCHANGE ACTIVITY»
PROGRAM OF PROFESSIONAL EDUCATIONAL

the second (Master) level of higher education

specialty: 076 – Entrepreneurship and Trade

field of knowledge: 07 – Management and Administration

qualification: Master in Entrepreneurship and Trade

APPROVED BY
THE ACADEMIC COUNCIL OF NTU "KhPI"

The Head of the Academic Council

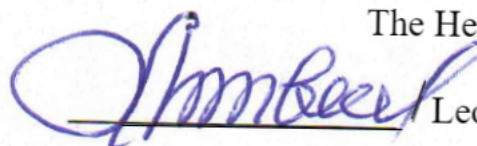
Leonid TOVAZHNYANSKYI

Protocol № 4

dated « 5 » May 2023

Kharkiv 2023

APPROVAL SHEET FOR

«ENTREPRENEURSHIP, TRADE AND EXCHANGE ACTIVITY» program of professional education

Level of higher education	Second (Master's)
Field of knowledge	07 Management and Administration
Major	076 «Entrepreneurship and Trade»
Qualification	Master in <u>Entrepreneurship and Trade</u>

APPROVED BY

OP Workgroup for major 076
«Entrepreneurship and Trade»

Head of Education Program

Olena SERHIENKO

« 04 » 05 2023 p.

Recommended by

Methodical Council of NTU «KhPI»
Deputy Head of Methodical Council

Ruslan MYHUSHCHENKO

« 04 » 05 2023 p.

AGREED UPON

Head of the Department of Entrepreneurship,
Trade and Logistics

Yevhen SHAPRAN

« 04 » 05 2023 p.

AGREED UPON

Deputy Director of Education and Research
Institute of Economics, Management and
International Business (EMIB)

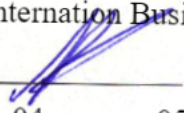
Oleksandr MANOYLENKO

« 04 » 05 2023 p.

AGREED UPON

Student (member of the OP working group)
study group BEM-M1022

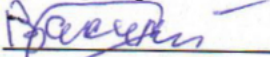
Alyona VASILIEVA

« 04 » 05 2023 p.

REVIEWERS

Productive comments and feedback on the educational program project were received from:

1. Kutsenko Tetiana Mykolaivna, PhD in Economics, Associate Professor, Associate Professor of the Department of Marketing, Management and Enterprise at V. N. Karazin Kharkiv National University.

2. Vlasenko Tetiana Anatoliivna, Doctor of Economics, Professor, Head of the Department of Enterprise Economics and Business Organization at S. Kuznets Kharkiv National University of Economics.

PREFACE

Corresponds to the Standard of higher education of the second (master's) level of the field of knowledge 07 "Management and administration", specialty 076 "Entrepreneurship and trade", approved and put into effect by the order of the Ministry of Education and Science of Ukraine № 961 of 10.07.2019.

Developed by the working group OP 076 "Entrepreneurship, trade and exchange activity" of the Educational and Scientific Institute of Economics, Management and International Business of the National Technical University "Kharkiv Polytechnic Institute".

as part of:

Guarantor of the educational program

SERHIENKO Olena Andrianivna, Doctor of Economic Sciences, Professor, Professor of the Department of Entrepreneurship, Trade and Logistics..

Members of the OP working group:

1. GAVRYS Mykola Oleksandrovysh, PhD in Economics, Professor, Professor of the Department of Entrepreneurship, Trade and Logistics.
2. STEPURINA Svitlana Oleksandrivna, PhD in Economics, Associate Professor, Associate Professor of the Department of Entrepreneurship, Trade and Logistics.
3. VASILIEVA Alyona Vitaliivna – student for the second level of higher education (master's degree) in "Entrepreneurship, Trade and Exchange Activities", group BEM-M1022

**1. PROFILE OF THE EDUCATIONAL PROGRAM
BY SPECIALTY
076 – ENTREPRENEURSHIP AND TRADE**

1 – General information	
Higher educational institution and structural division	National Technical University "Kharkiv Polytechnic Institute", Educational and Scientific Institute of Economics, Management and International Business, Department of Entrepreneurship, Trade and Logistics.
The degree of higher education and the title of the qualification in the original language	Master's degree; Master of Entrepreneurship and Trade
The official name of the educational program	Educational and professional program "Entrepreneurship, trade and exchange activity"
Type of diploma and scope of the educational program	Master's degree, single, 90 ECTS credits, study period 1 year 4 months
Availability of accreditation	Ministry of Education and Science of Ukraine. ND certificate No. 2192153 valid until July 1, 2025.
Cycle/level	the second (master's) level of higher education; NRC of Ukraine - 7th level; EQF-7 level; QF-EHEA – the second cycle
Prerequisites	Possession of a bachelor's, specialist's, master's degree
Language of teaching	Ukrainian language, English
The term of validity of the educational program	According to the validity period of the accreditation certificate. Reviewed annually
Link to the permanent posting of the description of the educational program	http://blogs.kpi.kharkov.ua/v2/quality/op-magistr-2023/

2 – The purpose of the educational program	
Training of specialists capable of solving complex tasks and problems in the field of entrepreneurship, trade and exchange activity or in the learning process, which involves conducting research and/or implementing innovations under uncertain conditions and requirements.	
3 – Characteristics of the educational program	
Subject area (field of knowledge, specialty)	<ul style="list-style-type: none"> * Objects of study: the activities of business entities of entrepreneurial, trade and/or exchange activity in the production and circulation of goods and services, which is carried out in order to ensure their effective management and development. * Learning goals: training specialists capable of solving complex tasks and problems in the field of entrepreneurship, trade, and exchange activity or in the learning process, which involves conducting research and/or implementing innovations under uncertain conditions and requirements. * Theoretical content of the subject area: scientific theories, provisions, concepts, principles of entrepreneurship, trade, and exchange activity and the methodology of their use for effective management and development of business and trade structures. * Methods, techniques and technologies: a system of innovative methods, professional management techniques and technologies. * Tools and equipment: information and communication systems, devices and equipment (computer equipment, specialized software).
Orientation of the educational program	Educational and professional program with applied orientation. The structure of the program involves dynamic, integrative and interactive learning. Focuses on modern scientific research in the field of entrepreneurship, trade, stock exchange and commercial activities, takes into account the specifics of work in the specified field; is based on project and tested practical results, taking into account the state of development of innovations, prospects for their use and implementation.
Main focus of the educational program and specialization	Special education in the specialty 076 "Entrepreneurship and Trade". Keywords: entrepreneurship, trade, stock exchange activity, enterprise economics, commercial business.
Features of the program	The program is multidisciplinary and provides practical training to develop skills in entrepreneurship, trading and stock exchange activities.
4 – Suitability of graduates for employment and further education	
Suitability for employment	Graduates can work in the following professions (according to the National Classifier of Professions DK 003:2010): 1238 Head of the institution (structural unit) for standardization,

	<p>certification and quality; 2419.2 business efficiency specialist, quality specialist; 3449 state inspector for product quality and trade; 3152 product quality control inspector; 1493 manager of quality systems; 1314 director (head) of a small trading firm; 1452 manager in wholesale trade; 1453 manager in retail trade of household and non-food goods; specialist in exchange operations; 2413.2 професіонал-організатор торгівлі на ринку цінних паперів; 2413.2 professional organizer of trading on the securities market; 3417 auctioneer; 2413.1 researcher (stock exchange operations); 1475.4 logistics manager 2419.2 logistician</p>
Further training	Continuing education at the third (educational and scientific) level of higher education. Acquisition of additional qualifications in the system of postgraduate education.
5 – Teaching and assessment	
Teaching and learning	<p>Student-centered education, which is conducted in the form of lectures, seminars, practical classes, consultations, trainings, independent study, completion of coursework based on the study of textbooks, manuals, periodical scientific publications, use of the Internet.</p> <p>Problem-based learning, distance learning in the MS Office 365 system, self-study, learning through laboratory practice, research-based learning.</p> <p>Teaching is conducted in the form of: lectures, multimedia lectures, interactive lectures, seminars, practical classes, laboratory works. Independent work with the possibility of consultations with the teacher on individual educational components, individual classes, group project work is also provided.</p>
Assessment	Rating system. Current and final control of knowledge (surveys, control and individual tasks, testing, etc.), tests and exams (oral and written), defense of course projects and works, defense of practice report, public defense of qualification work.
6 – Program competencies	
Integral competence	The ability to solve complex tasks and problems in the field of entrepreneurship, trade and exchange activity or in the process of learning, which involves conducting research and/or carrying out innovations under uncertain conditions and requirements.
General	GC 1. Ability to adapt and act in a new situation.

<p>competences (defined by the standard of higher education of the specialty)</p>	<p>GC 2. The ability to identify, pose and solve problems. GC 3. Ability to motivate people and move towards a common goal. GC 4. Ability to communicate with representatives of other professional groups at different levels (with experts from other fields of knowledge/types of economic activity). GC 5. Determination and persistence in relation to assigned tasks and assumed responsibilities.</p>
<p>Special (professional) competences of the specialty (defined by the standard of higher education of the specialty)</p>	<p>SC 1. Ability to develop and implement a strategy for the development of business, trading and/or exchange structures. SC 2. Ability to evaluate products, goods and services in business, trading and/or exchange activities SC 3. Ability to effectively manage the activities of business entities in the field of entrepreneurship, trade and/or exchange activities. SC 4. Ability to solve problems and make management decisions in professional activities. SC 5. Ability to initiate and implement innovative projects in business, trading and/or exchange activities.</p>
7 – Learning outcomes	
<p>The outcomes of studies in the specialty (defined by the standard of higher education of the specialty)</p>	<ol style="list-style-type: none"> 1. Be able to adapt and take initiative and independence in situations that arise in professional activities. 2. Identify, analyze problems of entrepreneurship, trade and exchange activities and develop measures to address them. 3. Be able to develop measures of material and moral incentives and apply other tools to motivate staff and partners to achieve the goal. 4. Apply business communications to support interaction with representatives of different professional groups. 5. To be able to perform tasks in the field of entrepreneurship, trade and/or exchange activities professionally, in full and with creative self-realization. 7. Determine and implement strategic plans for the development of business entities in the field of entrepreneurship, trade and/or exchange activities. 8. Evaluate products, goods, services, as well as processes occurring in business, trading and/or exchange structures, and draw appropriate conclusions for making management decisions. 9. Develop and make decisions aimed at ensuring the efficiency of business entities in the field of business, trading and/or exchange activities. 10. Be able to solve problematic issues that arise in the activities of business, trading and/or exchange structures under conditions of uncertainty and risks. 11. Implement innovative projects to create conditions for the

	effective functioning and development of business, trading and/or exchange structures.
8 – Resource support for program implementation	
Staff support	Meets the staffing requirements for ensuring the implementation of educational activities in the field of higher education in accordance with the current legislation of Ukraine (Resolution of the Cabinet of Ministers of Ukraine "On Approval of the Licensing Conditions for the Conduct of Educational Activities of Educational Institutions" of
Material and technical support	December 30, 2015 No. 1187 (as amended by Resolution of the Cabinet of Ministers of Ukraine No. 365 of March 24, 2021). NTU "KhPI" has classrooms that meet the requirements for conducting classes under the program. The educational process uses the computer equipment of the departments, which meets the requirements for the quantity and quality of equipment.
Informational and educational and methodological support	Meets the technological requirements for educational, methodological and information support of educational activities in the field of higher education in accordance with the current legislation of Ukraine (Decree of the Cabinet of Ministers of Ukraine "On approval of licensing conditions for educational activities of educational institutions" dated December 30, 2015, No. 1187 (as amended, entered in accordance with the Resolution №. 365 of March 24, 2021). Access to the electronic repository of the scientific and technical library of NTU "KhPI" (eNTUKhPIIR) via the Internet (including the university Wi-Fi network).
9 – Academic mobility	
National credit mobility	On the basis of bilateral agreements between the National Technical University "Kharkiv Polytechnic Institute" and higher education institutions of Ukraine. The procedure for organizing academic mobility programs for participants in the educational process is regulated by the "Regulations on academic mobility of students, graduate students, doctoral students, scientific and pedagogical and scientific workers of NTU "KhPI", which is posted on the website of the educational department (http://blogs.kpi.kharkov.ua/v2/nv/dokumenti-ntu-hpi-2/). "The Regulation on the procedure for expulsion, suspension of studies, renewal and transfer of students of higher education, as well as granting them academic leave and the right to repeat studies at NTU "KhPI", which is also posted on the website of the educational department, establishes the procedure for expulsion, suspension of studies, renewal and transfer of persons

	<p>studying at educational programs licensed in accordance with the established procedure.</p> <p>The provision also applies to persons studying at accredited (if accreditation is provided for by national legislation) educational programs in educational institutions of foreign countries, in case of their renewal or transfer to NTU "KhPI".</p>
International credit mobility	<p>Regulated by the "Regulations on student training and internships (scientific internships) of post-graduate students, doctoral students, scientific and scientific-pedagogical workers in leading higher education institutions and scientific institutions abroad"</p> <p>(http://blogs.kpi.kharkov.ua/v2/nv/wp-content/uploads/sites/17/2019/11/POLOZHENNYA-pro-akademichnu-mobilnist-studentiv-universitetu-2018_final19.doc).</p> <p>Individual agreements on academic mobility for study and research in universities and scientific institutions of partner countries are allowed.</p> <p>On the basis of bilateral agreements between the National Technical University "Kharkiv Polytechnic Institute" and educational institutions of higher education of foreign partner countries.</p>
Training of foreign students	International students are taught in separate groups. International students can study on general terms or on an individual schedule.

2. LIST OF EDUCATIONAL COMPONENTS IN THEIR LOGICAL SEQUENCE

2.1 List of components of the OP

Code n/a	Components of the educational program (disciplines, projects/works, practice, qualification work)	Number of credits	Form of final control
1	2	3	4
Obligatory educational components			
<i>General training</i>			
GT1	Business ethics and social responsibility	3,0	Test
GT2	Business communication in a foreign language	3,0	Test
GT3	Contractal law	3,0	Test
<i>Special (professional) training</i>			
PT1	Basics of scientific research	4,0	Test

PT 2	Modern methods of business analytics in entrepreneurship and trade	5,0	Exam
PT 3	Technological Entrepreneurship and Stock Exchanges	4,0	Test
PT 4	Economic Efficiency of Business Solutions	5,0	Exam
PT 5	E-commerce and global entrepreneurship	4,0	Exam
PT 6	International Technical Regulation	6,0	Exam
PT 7	Pre-graduation practice	15,0	Test
PT	Attestation	15,0	
	The total amount of obligatory educational components	67	
Optional components OP			
	<i>Profile training *</i>	15	
	<i>The profiled package of disciplines 01 «Entrepreneurship, Trade and Exchange Activity»</i>		
OP 1.1	Merchandising	4,0	Exam
OP 1.2	Commercial Logistics	5,0	Exam
OP 1.3	Quality Management of Goods and Services	6,0	Exam
1	2	3	4
	<i>The profiled package of disciplines 02 "Corporate logistics and supply chain management "</i>		
OP 2.1	Innovative Management of Supply Chains	4,0	Exam
OP 2.2	Logistics Management	5,0	Exam
OP 2.3	Design of Logistics Systems	6,0	Exam
	<i>Optional components of the student of the profile preparation according to the list *</i>	8	
	The total amount of optional components:	23	
	GENERAL SCOPE OF THE EDUCATIONAL PROGRAM:	90	

Note *. The student chooses one of the profiled packages of OC disciplines (15 ECTS credits) and free-choice disciplines of ODP specialized training (8 ECTS credits) according to the list according to the curriculum

2.2 Structural and logical scheme of OP

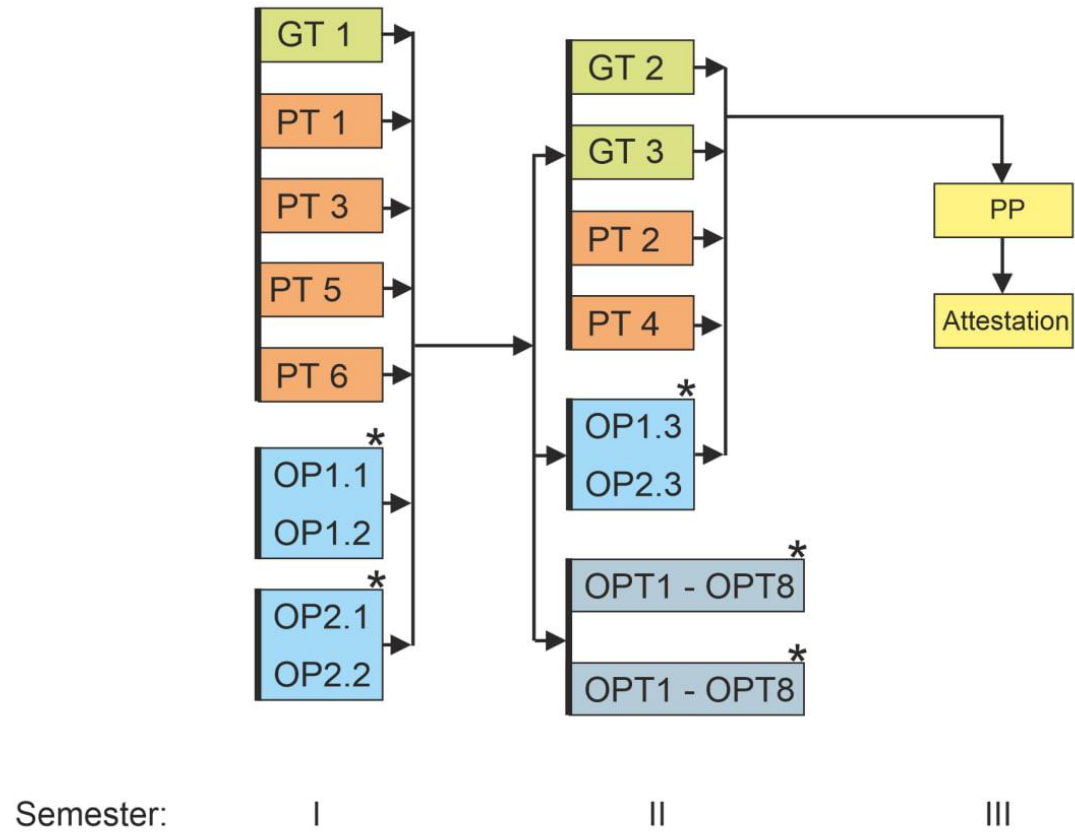

2.3 Distribution of the content of the educational program by component groups and training cycles

No n/p	Training cycle	The volume of the educational load of the student of higher education (ECTC credits / %)		
		Obligatory components of the educational and professional program	Optional components of the educational and professional	Total for the entire educational period
1	General training	9 / 10	-	9 / 10
2	Special (professional) training	58 / 64	-	58 / 64
3	Optional educational components	-	23 / 26	23 / 26
Total for the entire education period		67 / 74	23 / 26	90 / 100

3. FORM OF ATTESTATION OF APPLICANTS OF HIGHER EDUCATION

The attestation of applicants of higher education in the specialty 076 "Entrepreneurship, Trade, and Exchange Activities" is carried out openly in the form of a public defense of a qualification work (diploma project) and ends with the issuance of a document of the established model on awarding him with the degree of higher education "Master" with the assignment of an educational qualification: Master of Entrepreneurship and Trade.

The final qualifying work is checked for plagiarism and must be posted on the official website or in the repository of the higher education institution.

Table 1. Matrix of correspondence of defined learning outcomes, competencies and educational components

	GC1 Ability to adapt and act in a new situation	GC 2. Ability to identify, formulate and solve problems	GC 3. Ability to motivate people and move towards a common goal	GC 4. Ability to communicate with representatives of other professional groups of different levels (with experts from other fields of knowledge/ types of economic activity)	GC 5. Determination and perseverance in relation to the tasks and responsibilities.	SC 1. Ability to develop and implement a strategy for the development of business, trading and/or exchange structures	SC 2. Ability to evaluate products, goods and services in business, trading and/or exchange activities	SC 3. Ability to effectively manage the activities of business entities in the field of entrepreneurship, trade and/or exchange activities	SC 4. Ability to solve problems and make management decisions in professional activities.	SC 5. Ability to initiate and implement innovative projects in business, trading and/or exchange activities.
PLO1 Be able to adapt and show initiative and independence in situations that arise in professional activities.	GT1 GT2 PT1									
PLO2 Identify, analyze problems of entrepreneurship, trade and exchange activities and develop measures to solve them.		GT3 PT1 PT2 PT4								
PLO3 Be able to develop measures of material and moral incentives and apply other tools to motivate staff and partners to achieve the goal.			GT1 GT2							
PLO4 Apply business communications to support interaction with representatives of different professional groups..				GT1 GT2 GT3 PT3 PT6						
PLO5 Be able to perform tasks in the field of entrepreneurship, trade and/or stock exchange activities professionally, in full and with creative self-realization.					GT1 GT3 PT3 PT4 PT5					

	GC1. Ability to adapt and act in a new situation	GC 2. Ability to identify, formulate and solve problems	GC 3. Ability to motivate people and move towards a common goal	GC 4. Ability to communicate with representatives of other professional groups of different levels (with experts from other fields of knowledge/ types of economic activity)	GC 5. Determination and perseverance in relation to the tasks and responsibilities.	SC 1. Ability to develop and implement a strategy for the development of business, trading and/or exchange structures	SC 2. Ability to evaluate products, goods and services in business, trading and/or exchange activities	SC 3. Ability to effectively manage the activities of business entities in the field of entrepreneurship, trade and/or exchange activities	SC 4. Ability to solve problems and make management decisions in professional activities.	SC 5. Ability to initiate and implement innovative projects in business, trading and/or exchange activities.
PLO7 Identify and implement strategic plans for the development of business entities in the field of entrepreneurship, trade and/or stock exchange activities.						PT2 PT3 PT5 OP2.2				
PLO8 Evaluate products, goods, services, and processes occurring in business, trading, and/or exchange structures and draw appropriate conclusions for making management decisions.							PT1 PT2 PT4 OP1.1 OP1.3			
PLO9 Develop and make decisions aimed at ensuring the efficiency of business entities in the field of business, trading and/or exchange activities.							PT4 PT5 PT6 OP1.2			
PLO10 Be able to solve problematic issues that arise in the activities of business, trading and/or exchange structures under conditions of uncertainty and risks.								PT1 PT2 PT4 PT5		
PLO11 Implement innovative projects to create conditions for the effective functioning and development of business, trade and/or exchange structures.										PT3 PT6 OP2.1 OP2.3