

МІНІСТЕРСТВО ОСВІТИ І НАУКИ УКРАЇНИ

Національний технічний університет
"Харківський політехнічний інститут"



ЗАТВЕРДЖУЮ

Ректор НТУ «ХПІ»

Євген СОКОЛ

« 28 » 07 2024 р.

ОСВІТНЬО-ПРОФЕСІЙНА ПРОГРАМА «БІЗНЕС-АДМІНІСТРУВАННЯ» (англійською мовою)

Першого (бакалаврського) рівня вищої освіти
за спеціальністю 073 – Менеджмент
галузі знань 07 – Управління та адміністрування
кваліфікація бакалавр менеджменту

**ЗАТВЕРДЖЕНО
ВЧЕНОЮ РАДОЮ НТУ «ХПІ»**

Голова Вченої ради

Леонід ТОВАЖНЯНСЬКИЙ

Протокол № 6

від «05» липня 2024 р.

Харків 2024 р.

**ЛИСТ ПОГОДЖЕННЯ
освітньо-професійної програми**

Рівень вищої освіти	Перший (бакалаврський)
Галузь знань	07 Управління та адміністрування
Спеціальність	073 «Менеджмент»
Програма	Бізнес-адміністрування (англійською мовою навчання)
Кваліфікація	Бакалавр менеджменту

РОЗРОБЛЕНО

Робоча група зі спеціальності
«Менеджмент»
Гарант освітньої програми

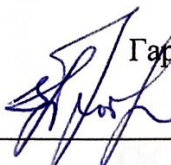
Олена ПРОХОРЕНКО
« 09 » 07 2024 р.

РЕКОМЕНДОВАНО

Методичною радою НТУ «ХПІ»
Заступник голови методичної ради

Руслан МИГУЩЕНКО
« 04 » 07 2024 р.

ПОГОДЖЕНО

Завідувачка кафедри менеджменту

Олена ПРОХОРЕНКО
« 04 » 07 2024 р.

ПОГОДЖЕНО

В.О.директора Навчально-наукового інституту
Економіки, менеджменту та міжнародного
бізнесу

Олександр МАНОЙЛЕНКО
« 04 » 07 2024 р.

ПОГОДЖЕНО

Здобувач (член робочої групи ОП)

гр. БЕМ-621ае

Дмитро ЧЕРЕДНИЧЕНКО
« 04 » 07 2024 р.

ЗАТВЕРДЖЕНО ТА НАДАНО ЧИННОСТІ

Наказом ректора Національного технічного університету «Харківський політехнічний інститут» від « 09 » 07 2024 р. № 253 00.

Ця освітньо-професійна програма не може бути повністю або частково відтворена, тиражована та розповсюджена без дозволу Національного технічного університету «Харківський політехнічний інститут».

FOREWORD

This programme was developed by the project group formed by the departments of management at the Institute of Education and Science in Economics, Management and International Business of National technical university “Kharkiv polytechnic institute”. The project group consisted of :

The Head of the project group (the programme guarantor) – Olena Prokhorenko, PhD (Management), associate professor of the department of management.

The members of the project group:

1. Koptieva Hanna - DSc (Economics&Management), Professor of the Department of Management.
2. Zamula Olena - PhD (Management), Associate Professor, Department of Management.
3. Cherednychenko Dmytro, 3rd year student

Reviews from external stakeholders:

1. Vyacheslav LEBEDYNETS, Sc.D, Deputy Director of Quality at "Aris LTD" LLC
2. Vissarion BUKHAIDZE, Director of "Seventy Five Engineering" LLC

РЕЦЕНЗІЯ

на освітню програму підготовки бакалавра «Бізнес-адміністрування
(англійською мовою навчання)» за спеціальністю 073 «Менеджмент»,
що реалізується у Національному технічному університеті
«Харківський політехнічний інститут»

Надана на рецензію освітня програма складена відповідно до Закону України «Про вищу освіту», Національної рамки кваліфікацій, Стандарту вищої освіти за спеціальністю 073 «Менеджмент» галузі знань 07 «Управління та адміністрування» для першого (бакалаврського) рівня вищої освіти.

Компоненти навчального плану формують необхідний склад інтегральних і фахових компетенцій, передбачених стандартом вищої освіти спеціальності 073 «Менеджмент», та дозволяють досягти визначених результатів навчання.

Компоненти обов'язкового блоку дозволяють реалізувати компетентнісний підхід до підготовки фахівців першого (бакалаврського) рівня вищої освіти. Програмою передбачено достатній обсяг практичної підготовки: ознайомчої практики «Вступ до фаху», виробничої та переддипломної практики.

Сформований блок вибіркових компонент дозволяє майбутнім фахівцям визначити професійне спрямування відповідно до власних інтересів та професійного кар'єрного спрямування: у сфері бізнес-комунікацій, фінансового супроводу, застосування діджитал-інструментів менеджменту, управління якістю.

Особливістю програми є підготовка англійською мовою, що створює для майбутніх фахівців додаткові можливості працевлаштування у міжнародних компаніях та розвитку власного міжнародного бізнесу.

Таким чином, вважаю, що освітньо-професійна програма «Бізнес-адміністрування (англійською мовою навчання)» в НТУ «ХПІ» відповідає сучасному рівню розвитку науки та практики освітньої діяльності, що дозволяє рекомендувати до використання цю програму для підготовки здобувачів вищої освіти на першому (бакалаврському) рівні за спеціальністю 073 «Менеджмент».

01.03.2024

Заступник директора з якості
д.фарм.н., професор

Вячеслав ЛЕБЕДИНЕЦЬ

РЕЦЕНЗІЯ

на освітню програму підготовки бакалавра «Бізнес-адміністрування
(англійською мовою навчання)» за спеціальністю 073 «Менеджмент»
що реалізується у Національному технічному університеті
«Харківський політехнічний інститут»

Освітньо-професійна програма розроблена кафедрою менеджменту НТУ «ХПІ», прийнятна для підготовки бакалаврів менеджменту з сучасним мисленням і компетентностями, необхідними для здійснення ефективної управлінської діяльності в бізнес-структурах.

Зміст програми відповідає Закону України «Про вищу освіту», Національній рамці кваліфікацій, Стандарту вищої освіти за спеціальністю 073 «Менеджмент» у галузі знань 07 «Управління та адміністрування» для першого (бакалаврського) рівня вищої освіти.

Особливістю програми є, по-перше, підготовка англійською мовою, що створює додаткові можливості майбутніх фахівців не тільки для працевлаштування, а й більш широкого кругозору та набуття знань з найкращих світових джерел. По-друге, вважаємо гарним здобутком запропоновані студентам освітні траєкторії, які дають змогу обрати більш прийнятну для себе професійну спрямованість.

Програма містить всі необхідні елементи, такі як мета, характеристика, перелік освітніх компонент та матриці відповідності програмних компетентностей та програмних результатів навчання відповідним компонентам. Перелік освітніх компонент має логічний і послідовний характер, і дозволяє реалізувати компетентнісний підхід до підготовки фахівців першого (бакалаврського) рівня вищої освіти.

Вважаємо що освітньо-професійна програма «Бізнес-адміністрування (англійською мовою навчання)» в НТУ «ХПІ» відповідає сучасному рівню вимог роботодавців, що дозволяє рекомендувати до використання цієї програми для підготовки здобувачів вищої освіти на першому (бакалаврському) рівні за спеціальністю 073 «Менеджмент».

Рецензент,
директор ТОВ
«СЕВЕНТИ ФАЙВ ІНЖИНІРИНГ»



Бухайдзе
Віссаріон Нодарійович

**I. PROFILE OF THE EDUCATIONAL AND PROFESSIONAL PROGRAMME
IN SPECIALTY 073 – MANAGEMENT**

1 – General information	
Full name of higher educational institution and structural unit	National technical university “Kharkiv polytechnic institute”; the institute of education and science in economics, management and international business; the department of management and taxation
The degree of higher education and qualification title	Bachelor, Bachelor of Management
Official name of the educational programme	The educational and professional programme “Business Administration” (In English)
Type of diploma and scope of the educational programme	Unitary, 240 ECTS credits, term of study - 3 years 10 months
Availability of accreditation	Certificate ДД 2192162, valid until July 1, 2025. Certificate of Central Evaluation and Accreditation Agency (ZEvA) dated 07.11.2023, valid until 30.09.2030, registered in НАЗЯВО (National agency for ensuring the quality of education, Ukraine) protocol No. 9(59) dated 16.04.2024.
Cycle/level	First (bachelor) level of higher education, National Qualification Framework (Ukraine) – 6th level, QF-LLL – 6th level, FQEHEA – first cycle
Prerequisites	complete general secondary education or educational degree "junior bachelor", professional "junior bachelor", OKR "junior specialist"
Language of instruction	English
The period of validity of the educational programme	According to the validity period of the certificate. Reviewed annually
Internet-address of the permanent description of the educational programme	https://blogs.kpi.kharkov.ua/v2/quality/dokumenty/diyuchy-osvitni-programy/
2 – The purpose of the educational programme	
To train professionals capable of solving practical problems and complex specialized tasks in the sphere of business management, due to developing a system of professional competencies	
3 – Characteristics of the educational programme	
Subject area (field of knowledge, specialty, specialization)	07 Management and Administration 073 Management
Orientation of the educational programme	The educational and professional programme has a practical orientation. The programme’s emphasis is on the formation of capabilities for carrying out administrative, entrepreneurial, and analytical activities using modern approaches and methods of managing business.
The main focus of the educational programme	Comprehensive general education in specialty 073 «Management».

and specialization	Keywords: management, organization, business, strategic management, planning, designing, entrepreneurship
Features of the programme	The programme is based on paradigms, laws, regularities, principles of management, and the historical background of its development. Specialized subject areas include cross-sectoral aspects of the development and making managerial decisions and are aimed at training specialists in the field of business, based on modern results and trends in business management. The programme provides training in English
4 – Suitability of graduates for employment and further training	
Suitability for employment	Graduates can work in the following groups of professions (according to the National Classifier of Professions DK 003:2010): 343 Technical specialists in the field of management 3435 Organizers of record keeping 3436 Assistant managers 3436.1 Assistant managers of enterprises, institutions and organizations 3436.2 Assistant managers of production and other main divisions 3436.3 Assistant managers of small enterprises without a management apparatus 3436.9 Other assistants 3439 Other technical specialists in the field of management
Further training	Graduates can continue their studies at the second (master's) level of higher education, as well as can get advanced training and acquire additional, post-qualifying education.
5 – Teaching and assessment	
Teaching and learning	Student-centered teaching in the form of lectures, seminars, practical classes, consultations. Classroom activities are supplemented by students' independent work, preparation of term papers based on working with textbooks, and scientific periodicals, data on the activities of business structures, and using the Internet resources/
Assessment	The rating system of assessment, presentations, project work, examinations, defense of internship reports, public defense of the qualification (bachelor's) work.
6 – Programme competencies	
Integral competency	The ability to solve complex specialized tasks and practical problems characterized by complexity and uncertainty of conditions in the management sphere or in the learning process, which involves the application of theories and methods of social and behavioral sciences The study of Ukrainian practice took into account the competencies that determine the regional context.
Generic competencies (GC)	GC01. The ability to realize own rights and responsibilities as a member of society, understand the values of civil (democratic) society and the need for its sustainable development, rule of law, human and civil rights, and freedoms in Ukraine. GC02. The ability to maintain and to increase the moral, cultural, scientific values and to increase achievements of society by understanding the history and patterns of data domain development, its place in the overall knowledge system about nature and society and in the development of society, techniques, and technologies, to

	<p>use different types and forms of motor activity for recreation and healthy lifestyles.</p> <p>GC03. The ability to abstract thinking, analysis, synthesis.</p> <p>GC04. The ability to apply knowledge in practical situations.</p> <p>GC05. Knowledge and understanding the subject area and understanding the professional activity.</p> <p>GC06. The ability to communicate by the national language both orally and in writing.</p> <p>GC07. The ability to communicate in a foreign language.</p> <p>GC08. Skills of information and communication technology usage.</p> <p>GC09. The ability to learn and to master modern knowledge.</p> <p>GC10. The ability to conduct research at an appropriate level.</p> <p>GC11. The ability to adapt and perform in a new situation.</p> <p>GC12. The ability to generate new ideas (creativity).</p> <p>GC13. The appreciation and respect for diversity and multiculturalism.</p> <p>GC14. The ability to work in an international context.</p> <p>GC15. The ability to act on the basis of ethical grounds (reasons).</p> <p>GC16. Ability to make decisions and act in accordance with the principle of inadmissibility of corruption and any other manifestations of dishonesty</p>
<p>Professional (specialty-specific) competencies (SC)</p>	<p>SC01. The ability to identify and describe the characteristics of organizations.</p> <p>SC02. The ability to analyze the results of organization activity, to compare them with the factors of the external and internal environment.</p> <p>SC03. The ability to identify prospects of organization development.</p> <p>SC04. The ability to determine the functional areas of the organization and the relationships between them.</p> <p>SC05. The ability to manage the organization and its units through the management functions realization</p> <p>SC06. The ability to act socially responsible and consciously.</p> <p>SC07. The ability to choose and to use modern tools of management.</p> <p>SC08. The ability to plan the organization activity and to manage the time.</p> <p>SC09. The ability to generate business ideas, to justify the feasibility and forms of their implementation as well as present them to stakeholders</p> <p>SC10. The ability to work in a team and to establish interpersonal interaction in solving professional tasks.</p> <p>SC11. The ability to create and manage effective communication in the process of management.</p> <p>SC12. The ability to analyze and structure the problems of an organization, to form reasonable decisions.</p> <p>SC13. To understand the principles and rules of law and to use them in a professional activity.</p> <p>SC14. To understand the principles of psychology and use them in a professional activity.</p> <p>SC15. The ability to form and demonstrate leadership and behavioral skills.</p> <p><i>Competencies additionally defined by this educational program</i></p>

	SC16. The ability to generate business ideas, to justify the feasibility and form of their implementation as well as to present them to stakeholders
7 – Programme learning outcomes	
Specialty-specific programme learning outcomes	<p>LO 01. To know the rights and duties as a member of society, be aware of the values of civil society, the rule of law, human and citizen rights, and freedoms in Ukraine.</p> <p>LO 02. To keep moral, cultural, scientific values and to increase achievements of society, to use different types and forms of effective activity for maintaining a healthy lifestyle.</p> <p>LO 03. To demonstrate knowledge of theories, methods and functions of management, modern concepts of leadership.</p> <p>LO 04. To show skills of identification of problems and justification of management decisions.</p> <p>LO 05. To describe the content of the functional areas of the organization</p> <p>LO 06. To show skills of search, collecting, and analysis of information, calculation of indicators to substantiate management decisions.</p> <p>LO 07. To show skills of organizational planning.</p> <p>LO 08. To apply management methods to ensure the effectiveness of the organization.</p> <p>LO 09. To plan and to organize an operational activities, to manage the business entity resources effectively.</p> <p>LO 10. To demonstrate skills of interaction, leadership, and teamwork.</p> <p>LO 11. To demonstrate the skills of analyzing the situation and communicating in various areas of the organization’s activities.</p> <p>LO 12. To evaluate the legal, social, and economic implications of an organization’s functioning.</p> <p>LO 13. To communicate in an oral and written form in the state and foreign languages.</p> <p>LO 14. To identify the stress reasons, to adapt yourself and members of the team to a stressful situation, to find means to its neutralization.</p> <p>LO 15. To show the ability to act socially responsibly and socially consciously on the basis of ethical reasons (motives), respect for a variety, and interlevel of culture.</p> <p>LO 16. To demonstrate skills of independent work, flexible thinking, openness to new knowledge, be critical and self-critical.</p> <p>LO 17. To conduct researches individually and/or in a group under the leadership of the leader.</p> <p><i>Program outcomes additionally defined by this educational program</i></p> <p>LO18. To be able to plan business activities and substantiate project proposals</p>
8 - Resource support for the implementation of the programme	
Personnel support	Meets the staffing requirements related to conducting educational activities in the sphere of higher education in accordance with current legislation of Ukraine (the Resolution of the Cabinet of Ministers of Ukraine “On approval of the licensing conditions for conducting educational activities of educational institutions” of December 30,

	2015, № 1187 (with the changes introduced in accordance with the Resolution of CM № 347 of 10.05.2018). The program is staffed by teachers who have English certificates at the level B2 and higher.
Material and technical support	Meets the technical requirements related to the material and technical base of educational activities in the sphere of higher education in accordance with current legislation of Ukraine (the Resolution of the Cabinet of Ministers of Ukraine “On approval of the licensing conditions for conducting educational activities of educational institutions” of December 30, 2015, № 1187 (with the changes introduced in accordance with the Resolution of CM № 347 of 10.05.2018))
Informational support and availability of instructional materials	Meets the technical requirements regarding informational support and availability of instructional materials for educational activities in the sphere of higher education in accordance with current legislation of Ukraine (the Resolution of the Cabinet of Ministers of Ukraine “On approval of the licensing conditions for conducting educational activities of educational institutions” of December 30, 2015, № 1187 (with the changes introduced in accordance with the Resolution of CM № 347 of 10.05.2018))
9- Academic mobility	
National Credit Mobility	Academic mobility is based on bilateral agreements between the National technical university “Kharkiv polytechnic institute” and other Ukrainian higher educational institutions
International Credit Mobility	The Programme is also conducted within the framework of the EU Erasmus+ program and provides for academic mobility on the basis of bilateral agreements between the National Technical University "Kharkiv Polytechnic Institute" and the University of Maribor (Slovenia); Rhine-Waal University of Applied Sciences (Germany); Sapienza University, (Rome, Italy), Istanbul Polytechnic University (Istanbul, Turkey).
Training of foreign applicants for higher education	Students are offered the opportunity to study in English.

2. The list of components of the educational and professional programme

Code	Components of the educational programme	Number of credits	Form of final assessment
1	2	3	4
1.Obligatory components of EP			
<i>1.1.General training</i>			
3П 1	History of Ukraine and Ukrainian culture	4	Exam
3П 2	Ukrainian Language	3	Exam
3П 3	Foreign Language*	17	Differentiated grading, Exam
3П 4	Philosophy	3	Exam
3П 5	Jurisprudence	4	Differentiated grading
3П 6	Economic Theory: Microeconomics	5	Exam
3П 7	Higher Mathematics	6	Exam
3П 8	Fundamentals of Entrepreneurship	5	Exam
3П 9	Information systems in economic activity	4	Differentiated grading
3П 10	Economic Theory. Macroeconomics	5	Exam
3П 11	Economic Statistics	4	Differentiated grading
3П 12	Physical education	12	Differentiated grading
<i>1.2.Professional training</i>			
СП 1	Introduction to Speciality (Introductory practice)	3	Differentiated grading
СП 2	Theory of Organization	5	Differentiated grading
СП 3	Accounting	5	Exam
СП 4	Enterprise Economics	5	Exam
СП 5	Marketing	5	Exam
СП 6	Fundamentals of Management	8	Differentiated grading, Exam
СП 7	International Business	6	Exam
СП 8	Human Resource Management	6	Exam
СП 9	Finance of Enterprises	5	Differentiated grading
СП 10	Riskology	4	Differentiated grading
СП 11	Fundamentals of business-analysis	5	Exam
СП 12	Self-management	5	Exam
СП 13	Business-modeling	6	Exam
СП 14	Business-communication	5	Exam
СП 15	Strategic Management	6	Exam
СП 16	Performance Management	6	Exam
СП 17	Business valuation	5	Exam
ПП1	Practical Training*	6	Differentiated grading
ПП2	Pre-graduation Practice*	6	Differentiated grading
A	Attestation	6	
Total amount for obligatory components		180	
2 Elective educational components			
2.1 Elective educational components from the general university catalogue of disciplines			

OK3П 1-3	Elective educational components 1-3	12	Differentiated grading
2.2 Elective educational components of the profile preparation according to the list			
OKБП 1-12	Elective educational components of the profile training 1-12	48	Differentiated grading
Total amount for elective components		60	
TOTAL AMOUNT FOR THE EDUCATIONAL PROGRAMME		240	

Annex

2.1	Optional student disciplines of the profile training	Semester
OKБП 1	Mathematical modeling in management	5
OKБП 2	Basics of project management	5
OKБП 3	Resource management	5
OKБП 4	Local studies (in Ukrainian)	5
OKБП 5	Research in international business	5
OKБП 6	Project financing and the basics of grant management (in Ukrainian)	5
OKБП 7	Management of export-import operations	6
OKБП 8	Organizational behavior	6
OKБП 9	Operational management	6
OKБП 10	Leadership (in Ukrainian)	6
OKБП 11	Introduction to computer science	6
OKБП 13	Insurance management	6
OKБП 14	Taxation	6
OKБП 15	Enterprise capital	6
OKБП 16	Management of international supply chains	7
OKБП 17	International teamwork and management of joint ventures	7
OKБП 18	Logistics	7
OKБП 19	International investment activity	7
OKБП 20	Digital etiquette in international communications	7
OKБП 21	International economic integration and international organizations	7
OKБП 22	Socially responsible marketing (in Ukrainian)	7
OKБП 23	Management of innovations	7
OKБП 24	Event management (in Ukrainian)	7
OKБП 25	SMM-Management	8
OKБП 26	Quality management	8
OKБП 27	Corporate social responsibility	8
OKБП 28	Electronic business	8
OKБП 29	Academic writing in international business	8
OKБП 30	PR tools in international relations	8
OKБП 31	Gender aspects of business	8
OKБП 32	Competitiveness management	8
OKБП 33	Fundraising	8
OKБП 34	Conflictology and negotiation theory	8
OKБП 35	Business tourism	8
OKБП 36	Intellectual property in innovative business activities (in Ukrainian)	8

4. ALLOCATION OF THE CONTENT OF THE EDUCATIONAL PROGRAMME AMONG GROUPS OF COMPONENTS AND TRAINING CYCLES

№	Training cycle	Academic load on applicants for higher education (credits / %)		
		Obligatory components of the educational and professional programme	Optional components of the educational and professional programme	Total number for the entire period of study
1	2	3	4	5
1	General training cycle	72 / 30	12 / 5	84 / 35
2	Professional and practical training cycle	108 / 45	48 / 20	156 / 65
Total number for the entire period of study		180 / 75	180 / 75	60 / 25

5. FORM OF CERTIFICATION OF APPLICANTS FOR HIGHER EDUCATION

Certification of graduates of the educational programme in specialty 073 «Management» is carried out in the form of a public defence of the qualification work and ends with the issuance of the document of a standard form on awarding a Bachelor's degree and the qualification "Bachelor of Management".

The attestation takes place openly and publicly.

3. STRUCTURAL-LOGICAL SCHEME OF THE EDUCATIONAL PROGRAMME

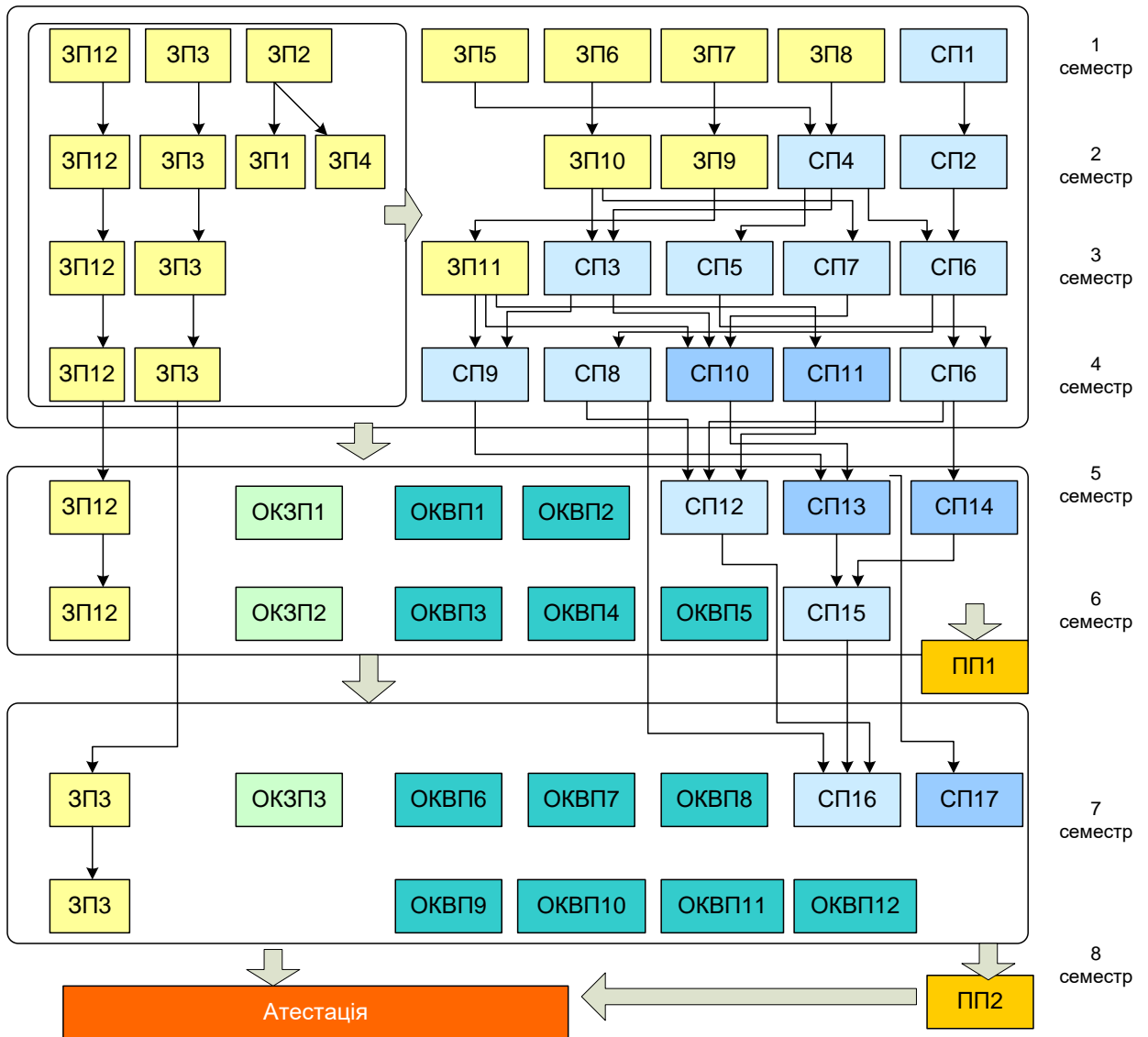

6.1 Matrix of correspondence between learning outcomes, general competencies and educational components

learning outcomes	competencies															
	Integral competency															
	general competencies															
	GC01	GC02	GC03	GC04	GC05	GC06	GC07	GC08	GC09	GC10	GC11	GC12	GC13	GC14	GC15	GC16
LO 1	ЗП1															
LO 2		ЗП1, ЗП12														
LO 3				СП8, СП16, ПП1	ЗП6, ЗП10 СП15, СП16				СП8	СП15						
LO 4				ЗП8, СП11, СП16, ПП2							СП10, СП15	СП15				
LO 5																
LO 6								ЗП9, ЗП11, СП5, СП9	ЗП6, ЗП10							
LO 7																
LO 8													СП8, СП7			
LO 9																
LO 10											СП6					
LO 11			СП9, СП16					СП12, ПП1, ПП2								
LO 12															СП8, ЗП8, СП2	
LO 13						ЗП2, СП12	ЗП3, СП14							ЗП3, СП7, СП5		
LO 14															СП8	
LO 15												ЗП5, СП5				ЗП5
LO 16									ЗП4, СП2, СП4		ЗП8, СП6					
LO 17			ЗП7, ЗП11, СП3, СП9, СП16							ЗП7, СП8, СП11, СП15				СП7		
LO 18			СП10			СП14		СП14				СП10				

6.2 Matrix of correspondence between learning outcomes, professional competencies and educational components

learning outcomes	competencies															
	Integral competency															
	professional competencies															
	SC01	SC02	SC03	SC04	SC05	SC06	SC07	SC08	SC09	SC10	SC11	SC12	SC13	SC14	SC15	SC16
LO 1						ЗП5										
LO 2																
LO 3			СП15, СП16	СП15, СП16	СП8, СП15, СП16						СП6					
LO 4	СП9, СП12, СП16									СП8, СП11		СП9, СП10				СП13
LO 5	СП2, СП6, СП4, СП16		СП2, СП15, СП16								СП6, СП8					
LO 6		СП3, СП5, СП6, СП10, СП11, СП17								ЗП11, СП6,		СП3, СП4, СП6, СП9, СП10				СП10
LO 7	СП2	СП2, СП13	СП2, СП10, СП13	СП2, СП15, СП13												СП10
LO 8	СП6, СП16	СП6, СП7, СП15, СП16			СП6, СП8	СП6	СП6, СП8, СП15, СП16				СП6, СП8					
LO 9					СП16			СП12					СП12		СП1, СП16	СП13
LO 10				СП6, СП16												
LO 11											СП8, СП7,					
LO 12							СП8, ПП2							СП8, СП14	ЗП8	СП17
LO 13											СП7, СП8, СП14					СП14
LO 14													СП8		СП14	
LO 15							СП8,							СП8, СП14	ЗП8	
LO 16																
LO 17									СП1, СП8, СП12,							СП17
LO 18		СП10, СП17	СП10, СП13, СП17						СП10, СП13	СП14	СП17					