

MINISTRY OF EDUCATION AND SCIENCE OF UKRAINE  
National technical university "Kharkiv polytechnic institute"



**APPROVED**

The Rector of NTU "KhPI"

  
Yevgen SOKOL

22 » april 2025

**EDUCATIONAL AND PROFESSIONAL PROGRAMME**  
**«BUSINESS ADMINISTRATION**  
**(In English)»**

The first (bachelor) level of higher education  
in specialty **D3 – Management**  
in the field of knowledge **D – Business, Administration and Law**  
qualification **Bachelor of Management**

**APPROVED BY**  
**THE ACADEMIC COUNCIL OF NTU "KhPI"**

The Head of the Academic Council  
 / Yevgen SOKOL

Protocol № 4

dated « 28 » march 2025

Kharkiv 2025\_

**APPROVAL SHEET**  
**for the educational and professional programme “Business Administration (In English)”**

Level of higher education	First (bachelor)
Field of knowledge	D Business, Administration and Law
Specialty	D3 «Management»
Educational programme	Business Administration (In English)
Qualification	Bachelor of Management

**DEVELOPED**  
by the project group in the specialty  
"Management"  
Guarantor of the educational programme

  
\_\_\_\_\_ Olena PROKHORENKO  
« 20 » 03 \_\_\_\_\_ 2025 p.

**RECOMMENDED**  
by the Methodological Council  
of NTU “KhPI”  
Deputy Head of  
the Methodological Council

  
\_\_\_\_\_ Ruslan MYGUSHCHENKO  
« 26 » 03 \_\_\_\_\_ 2025

**AGREED**  
Head of the Department of  
Management

  
\_\_\_\_\_ Nataliia SHMATKO  
« 20 » 03 \_\_\_\_\_ 2025 .

**AGREED**  
Director of the Institute of Education and  
Science in Economics, Management and  
International Business

  
\_\_\_\_\_ Taras DANKO  
« 25 » 03 \_\_\_\_\_ 2025

**AGREED**  
Programme student

  
\_\_\_\_\_ Dmytro CHEREDNYCHENKO  
« 20 » 03 \_\_\_\_\_ 2025 .

**APPROVED AND PUT INTO EFFECT**

by the Order of the Rector of National technical university “Kharkiv polytechnic institute”  
of « 02 » 04 \_\_\_\_\_ 2025 № 11104.

*This educational and professional programme may not be reproduced or distributed, in whole or in part, without permission of National technical university “Kharkiv polytechnic institute”.*

## **REVIEWS FROM EXTERNAL STAKEHOLDERS:**

1. Olena RODIONOVA, Deputy Director of Finance at "Aris LTD" LLC
2. Lyudmila GOROKHOVA, Director of Ukrainian Association for Management Development and Business Education (UAMDBE)

## РЕЦЕНЗІЯ

### На освітню програму підготовки бакалавра за спеціальністю D3 Менеджмент «Бізнес-адміністрування. Англійською мовою навчання», що реалізується в Національному технічному університеті «Харківський політехнічний інститут»

Як представник бізнес-середовища, вважаю освітню програму «Бізнес-адміністрування (англійською мовою навчання)» надзвичайно актуальною та затребуваною. Бізнес сьогодні потребує фахівців, які вільно володіють англійською мовою, орієнтуються в міжнародних стандартах управління, мають стратегічне мислення та здатність швидко приймати управлінські рішення.

Програма дає студентам необхідну базу знань з менеджменту, фінансів, маркетингу, бізнес-комунікацій, а також формує практичні навички завдяки роботі з кейсами, груповим проектам та стажуванню. Для роботодавця важливо, що випускники здатні працювати в мультикультурному середовищі, проявляти ініціативність, відповідальність і лідерські якості.

Особливо цінним є акцент на комунікативних навичках та критичному мисленні. Це ті компетенції, які дозволяють молодим менеджерам швидко інтегруватися в робочі процеси та брати участь у розвитку компанії.

Бажано, аби програма у вибірковій частині включала курси з управління операціями, з цифрових технологій у бізнесі, оскільки саме ці напрями найбільш активно розвиваються у сучасному світі.

Загалом вважаю програму конкурентною та практикоорієнтованою. Випускники, підготовлені за цією освітньою програмою, мають гарні перспективи працевлаштування як в Україні, так і за кордоном.

Заступник директора  
Фінансовий



Олена РОДІОНОВА



## РЕЦЕНЗІЯ

На освітню програму підготовки бакалавра за спеціальністю D3 Менеджмент «Бізнес-адміністрування. Англійською мовою навчання», що реалізується в Національному технічному університеті «Харківський політехнічний інститут»

Освітньо-професійна програма підготовки бакалавра зі спеціальності D3 «Менеджмент» за освітньою програмою «Бізнес-адміністрування (англійською мовою навчання)» відповідає сучасним вимогам до підготовки висококваліфікованих фахівців у сфері управління.

Надана на рецензію програма складена відповідно до Закону України «Про вищу освіту», Національної рамки кваліфікацій, Стандарту вищої освіти за спеціальністю D3 «Менеджмент» для першого (бакалаврського) рівня вищої освіти. Компоненти навчального плану формують необхідний склад інтегральних і фахових компетентностей, передбачених стандартом вищої освіти спеціальності, та дозволяють досягти визначених результатів навчання.

Програма сформована з урахуванням компетентнісного підходу та спрямована на формування у студентів глибоких знань із менеджменту, економіки, маркетингу, фінансів, а також розвитку аналітичних, комунікативних і лідерських навичок. Значною перевагою є використання англійської мови як мови навчання, що забезпечує міжнародну конкурентоспроможність випускників, розширює їхні можливості працевлаштування та участі в програмах академічної мобільності.

Сильними сторонами програми є:

- орієнтація на інтеграцію в міжнародний освітній простір;
- поєднання теоретичної підготовки з практичною складовою (практики, бізнес-кейси, проєктна діяльність);
- акцент на розвитку soft skills поряд із професійними знаннями;
- сучасний зміст навчальних компонентів, що відповідає тенденціям глобального бізнес-середовища.



Доцільно було б включити в перелік вибіркових компонентів курси, що спрямовані на інноваційний менеджмент та цифрову трансформацію бізнесу.

У цілому програма є якісною, сучасною та перспективною, відповідає стандарту вищої освіти та здатна забезпечити підготовку конкурентоспроможних менеджерів нового покоління.

Директор УАРМБО



Л.П. Горохова

## FOREWORD

Complies with the Higher Education Standard in the specialty D3 "Management" for the first (bachelor's) level (Order of the Ministry of Education and Science No. 1165 dated 10/29/2018) and the Resolution of the Cabinet of Ministers No. 734 dated 06/21/2024 "On approval of the Procedure for conducting basic military training of citizens of Ukraine who are pursuing higher education and police officers"

This programme was developed by the project group formed by the departments of management at the Institute of Education and Science in Economics, Management and International Business of National technical university "Kharkiv polytechnic institute". The project group consisted of :

**The Head of the project group** (the programme guarantor) – Olena Prokhorenko, PhD (Management), professor of the department of management.

**The members of the project group:**

1. Koptieva Hanna - DSc (Economics&Management), Professor of the Department of Management.
2. Zamula Olena - PhD (Management), Associate Professor, Department of Management.
3. Cherednychenko Dmytro, student of the Programme

## I. PROFILE OF THE EDUCATIONAL AND PROFESSIONAL PROGRAMME IN SPECIALTY D3 – MANAGEMENT

<b>1 – General information</b>	
Full name of higher educational institution and structural unit	National technical university “Kharkiv polytechnic institute”; the institute of education and science in economics, management and international business; the department of management and taxation
The degree of higher education and qualification title	Bachelor, Bachelor of Management
Form of study	Institutional (full-time), part-time, distance
Professional qualification	No professional standard Professional qualification is not awarded
Official name of the educational programme	The educational and professional programme “Business Administration (In English)”
Type of diploma and scope of the educational programme	Unitary, 240 ECTS credits, term of study - 3 years 10 months
Availability of accreditation	Certificate of Central Evaluation and Accreditation Agency (ZEvA) dated 07.11.2023, valid until 30.09.2030, registered in НАЗРВО (National agency for ensuring the quality of education, Ukraine) protocol No. 9(59) dated 16.04.2024.
Cycle/level	First (bachelor) level of higher education, National Qualification Framework (Ukraine) – 6th level, QF-LLL – 6th level, FQEHEA – first cycle
Prerequisites	complete general secondary education or educational degree "junior bachelor", professional "junior bachelor", OKR "junior specialist"
Language of instruction	English
The period of validity of the educational programme	According to the validity period of the certificate. Reviewed annually
Internet-address of the permanent description of the educational programme	<a href="https://blogs.kpi.kharkov.ua/v2/quality/dokumenty/diyuchy-osvitnij-programy/osvitnij-riven-bakalavr/vstup-2025-2026-navchalnogo-roku/">https://blogs.kpi.kharkov.ua/v2/quality/dokumenty/diyuchy-osvitnij-programy/osvitnij-riven-bakalavr/vstup-2025-2026-navchalnogo-roku/</a>
<b>2 – The purpose of the educational programme</b>	
<p>To prepare specialists capable of solving practical problems and complex specialized tasks in the field of business management on the basis of mastering a system of competencies that corresponds to the strategic direction of the university in the field of compliance with the requirements of the modern domestic and foreign labor market and deepening the language training of students. The goal of the program is to ensure the acquisition of fundamental knowledge, practical skills and management competencies necessary for effective business management, making strategic and operational decisions in a dynamic market environment. The program is aimed at developing in students the ability to analyze business processes, develop and implement management strategies, introduce innovations, and work in a multicultural environment. The educational program opens up opportunities for building a successful career in the field of business management, in particular in the positions of middle manager, business analyst, entrepreneur, project manager, management consultant, etc. At the same time, it</p>	

provides a solid academic foundation for further study at the second (master's) level in the fields of management, economics, international business, public administration, and related fields, both in Ukraine and abroad.

**3 – Characteristics of the educational programme**

<p>Subject area (field of knowledge, specialty, specialization)</p>	<p>D Business, Administration and Law D3 Management Specialization: none <b>Object of study:</b> Management of organizations and their units <b>Learning objectives:</b> Training specialists capable of solving practical problems and complex specialized tasks characterized by complexity and uncertainty of conditions in the field of management of organizations and their units. <b>Theoretical content</b> of the subject area: paradigms, laws, patterns, principles, historical prerequisites for the development of management; concepts of systemic, situational, adaptive, anticipatory, anti-crisis, innovative, project management, etc.; functions, methods, technologies in management as well as managerial decisions. <b>Methods, techniques and technologies:</b> General scientific and specific research methods such as calculation and analytical, economic and statistical, economic and mathematical, expert evaluation, factual, sociological, documentary, balance sheet, etc.; methods of implementing management functions (marketing research; economic diagnostics; forecasting and planning; designing organizational management structures; motivation; control; methods of assessing social, organizational and economic efficiency in management, etc.). Management methods (administrative, economic, socio-psychological, technological); technologies for substantiating managerial decisions (economic analysis, simulation modelling, decision tree, etc.). <b>Tools and equipment:</b> Modern information and communication equipment, information systems and software products used in management.</p>
<p>Orientation of the educational programme</p>	<p>The educational and professional programme has a practical orientation. The programme's emphasis is on the formation of capabilities for carrying out administrative, entrepreneurial, and analytical activities using modern approaches and methods of managing business.</p>
<p>The main focus of the educational programme and specialization</p>	<p>Comprehensive general education in specialty D3 «Management». Keywords: management, organization, business, strategic management, planning, projecting, entrepreneurship</p>
<p>Features of the programme</p>	<p>The programme is based on paradigms, laws, regularities, principles of management, and the historical background of its development. Specialized subject areas include cross-sectoral aspects of the development and making managerial decisions and are aimed at training specialists in the field of business, based on modern results and trends in business management. The programme provides training in English and provides opportunities for academic mobility based on bilateral agreements between the National Technical University "Kharkiv Polytechnic Institute" and Lodz University of</p>

	Technology (Lodz, Poland); Rhine-Waal University of Applied Sciences (Germany); Sapienza University (Rome, Italy).
<b>4 – Suitability of graduates for employment and further training</b>	
Suitability for employment	<p>Graduates can work in the following groups of professions (according to the National Classifier of Professions DK 003:2010):</p> <p>343 Technical specialists in the field of management  3435 Organizers of record keeping  3436 Assistant managers  3436.1 Assistant managers of enterprises, institutions and organizations  3436.2 Assistant managers of production and other main divisions  3436.3 Assistant managers of small enterprises without a management apparatus  3436.9 Other assistants  3439 Other technical specialists in the field of management</p> <p>According to International Standard Classification of Occupations 2008 (ISCO-O8)</p> <p>24 Business and Administration Professionals  242 Administration Professionals  2421 Management and Organization Analysts  2422 Policy Administration Professionals  2423 Personnel and Careers Professionals  2424 Training and Staff Development Professionals  33 Business and Administration Associate Professionals  332 Sales and Purchasing Agents and Brokers  333 Business Services Agents  334 Administrative and Specialized Secretaries</p>
Further training	Graduates can continue their studies at the second (master's) level of higher education, as well as can get advanced training and acquire additional, post-qualifying education.
<b>5 – Teaching and assessment</b>	
Teaching and learning	Student-centered teaching in the form of lectures, seminars, practical classes, consultations. Classroom activities are supplemented by students' independent work, preparation of term papers based on working with textbooks, and scientific periodicals, data on the activities of business structures, and using the Internet resources
Assessment	The rating system of assessment, presentations, project work, examinations, defense of internship reports, public defense of the qualification (bachelor's) thesis
<b>6 – Programme competencies</b>	
Integral competency	The ability to solve complex specialized tasks and practical problems characterized by complexity and uncertainty of conditions in the management sphere or in the learning process, which involves the application of theories and methods of social and behavioral sciences The study of Ukrainian practice took into account the competencies that determine the regional context.
Generic competencies (GC)	GC01. The ability to realize own rights and responsibilities as a member of society, understand the values of civil (democratic)

	<p>society and the need for its sustainable development, rule of law, human and civil rights, and freedoms in Ukraine.</p> <p>GC02. The ability to maintain and to increase the moral, cultural, scientific values and to increase achievements of society by understanding the history and patterns of data domain development, its place in the overall knowledge system about nature and society and in the development of society, techniques, and technologies, to use different types and forms of motor activity for recreation and healthy lifestyles.</p> <p>GC03. The ability to abstract thinking, analysis, synthesis.</p> <p>GC04. The ability to apply knowledge in practical situations.</p> <p>GC05. Knowledge and understanding the subject area and understanding the professional activity.</p> <p>GC06. The ability to communicate by the national language both orally and in writing.</p> <p>GC07. The ability to communicate in a foreign language.</p> <p>GC08. Skills of information and communication technology usage.</p> <p>GC09. The ability to learn and to master modern knowledge.</p> <p>GC10. The ability to conduct research at an appropriate level.</p> <p>GC11. The ability to adapt and perform in a new situation.</p> <p>GC12. The ability to generate new ideas (creativity).</p> <p>GC13. The appreciation and respect for diversity and multiculturalism.</p> <p>GC14. The ability to work in an international context.</p> <p>GC15. The ability to act on the basis of ethical grounds (reasons).</p> <p>GC16. Ability to make decisions and act in accordance with the principle of inadmissibility of corruption and any other manifestations of dishonesty</p>
<p>Professional (specialty-specific) competencies (SC)</p>	<p>SC01. The ability to identify and describe the characteristics of organizations.</p> <p>SC02. The ability to analyze the results of organization activity, to compare them with the factors of the external and internal environment.</p> <p>SC03. The ability to identify prospects of organization development.</p> <p>SC04. The ability to determine the functional areas of the organization and the relationships between them.</p> <p>SC05. The ability to manage the organization and its units through the management functions realization</p> <p>SC06. The ability to act socially responsible and consciously.</p> <p>SC07. The ability to choose and to use modern tools of management.</p> <p>SC08. The ability to plan the organization activity and to manage the time.</p> <p>SC09. The ability to generate business ideas, to justify the feasibility and forms of their implementation as well as present them to stakeholders</p> <p>SC10. The ability to work in a team and to establish interpersonal interaction in solving professional tasks.</p> <p>SC11. The ability to create and manage effective communication in the process of management.</p> <p>SC12. The ability to analyze and structure the problems of an organization, to form reasonable decisions.</p>

	<p>SC13. To understand the principles and rules of law and to use them in a professional activity.</p> <p>SC14. To understand the principles of psychology and use them in a professional activity.</p> <p>SC15. The ability to form and demonstrate leadership and behavioral skills.</p> <p><i>Competencies additionally defined by this educational program</i></p> <p>SC16. The ability to generate business ideas, to justify the feasibility and form of their implementation as well as to present them to stakeholders</p>
<b>7 – Programme learning outcomes</b>	
<p>Specialty-specific programme learning outcomes</p>	<p>LO 01. To know the rights and duties as a member of society, be aware of the values of civil society, the rule of law, human and citizen rights, and freedoms in Ukraine.</p> <p>LO 02. To keep moral, cultural, scientific values and to increase achievements of society, to use different types and forms of effective activity for maintaining a healthy lifestyle.</p> <p>LO 03. To demonstrate knowledge of theories, methods and functions of management, modern concepts of leadership.</p> <p>LO 04. To show skills of identification of problems and justification of management decisions.</p> <p>LO 05. To describe the content of the functional areas of the organization</p> <p>LO 06. To show skills of search, collecting, and analysis of information, calculation of indicators to substantiate management decisions.</p> <p>LO 07. To show skills of organizational planning.</p> <p>LO 08. To apply management methods to ensure the effectiveness of the organization.</p> <p>LO 09. To plan and to organize an operational activities, to manage the business entity resources effectively.</p> <p>LO 10. To demonstrate skills of interaction, leadership, and teamwork.</p> <p>LO 11. To demonstrate the skills of analyzing the situation and communicating in various areas of the organization’s activities.</p> <p>LO 12. To evaluate the legal, social, and economic implications of an organization’s functioning.</p> <p>LO 13. To communicate in an oral and written form in the state and foreign languages.</p> <p>LO 14. To identify the stress reasons, to adapt yourself and members of the team to a stressful situation, to find means to its neutralization.</p> <p>LO 15. To show the ability to act socially responsibly and socially consciously on the basis of ethical reasons (motives), respect for a variety, and interlevel of culture.</p> <p>LO 16. To demonstrate skills of independent work, flexible thinking, openness to new knowledge, be critical and self-critical.</p> <p>LO 17. To conduct researches individually and/or in a group under the leadership of the leader.</p> <p><i>Program outcomes additionally defined by this educational program</i></p> <p>LO18. To be able to plan business activities and substantiate project proposals</p>

<b>8 - Resource support for the implementation of the programme</b>	
Personnel support	Meets the staffing requirements related to conducting educational activities in the sphere of higher education in accordance with current legislation of Ukraine (the Resolution of the Cabinet of Ministers of Ukraine “On approval of the licensing conditions for conducting educational activities of educational institutions” of December 30, 2015, № 1187 (with the changes introduced in accordance with the Resolution of CM № 347 of 10.05.2018). The program is staffed by teachers who have English certificates at the level B2 and higher.
Material and technical support	Meets the technological requirements for the material and technical support of educational activities in the field of higher education in accordance with the current legislation of Ukraine (Resolution of the Cabinet of Ministers of Ukraine “On Approval of the Licensing Conditions for the Conduct of Educational Activities of Educational Institutions” dated December 30, 2015 No. 1187 (as amended by Resolution of the Cabinet of Ministers of Ukraine No. 347 dated May 10, 2018, No. 180 dated March 3, 2020, No. 365 dated March 24, 2021) The educational process uses lecture halls, rooms for practical classes and consultations as well as Office 365 application, email, MS Teams, ClassNote, OneNote.
Informational support and availability of instructional materials	The information and educational support of the educational program must comply with the Resolution of the Cabinet of Ministers of Ukraine dated 12/30/2015 No. 1187 “On Approval of the Licensing Conditions for the Conduct of Educational Activities of Educational Institutions” (as amended by the Resolution of the Cabinet of Ministers of Ukraine No. 365 dated 03/24/2021. Appendix 18). The university library provides access to its own and external information resources, ensures the functioning of the information system, Wi-Fi; availability in remote mode 24/7 of information services and resources. Material and technical resources allow students of the Program to access the available educational and methodological support in the repository of NTU “KhPI” and on the website of the Department of Management. External resources: information and analytical (Web of Science, Scopus, SciVal platforms); full-text (ScienceDirect, Research4Life, Springer Nature); distance learning platforms (Дія.Освіта, Prometheus, Coursera, Udemy). Basic literature - Менеджмент : навч. посібник / Н. С. Краснокутська [та ін.] ; Нац. техн. ун-т "Харків. політехн. ін-т". – Харків : Друкарня Мадрид, 2019. – 231 с. <a href="https://repository.kpi.kharkov.ua/handle/KhPI-Press/40291">https://repository.kpi.kharkov.ua/handle/KhPI-Press/40291</a> - Менеджмент: організаційна ефективність [Електронний ресурс] : навч. посібник для бакалаврів РТец. 073 "Менеджмент" / Н. М. Шматько, М. В. Кармінська-Белоброва, О. В. Замула [та ін.]. – Електрон. текст. дані. – Харків : НТУ "ХПІ", 2024. – 280 с. <a href="https://repository.kpi.kharkov.ua/handle/KhPI-Press/85920">https://repository.kpi.kharkov.ua/handle/KhPI-Press/85920</a> - Горовий Д. А. Бізнес-діагностика [Електронний ресурс] : навч. посібник. Ч. 1. Фінансова діагностика / Д. А. Горовий, О. В. Прохоренко ; Нац. техн. ун-т "Харків. політехн. ін-т". –

	<p>Електрон. текст. дані. – Харків : НТУ "ХПІ", 2025. – 237 с. – URI: <a href="https://repository.kpi.kharkov.ua/handle/KhPI-Press/88336">https://repository.kpi.kharkov.ua/handle/KhPI-Press/88336</a></p> <p>- Drucker, Peter. The practice of management. Routledge, 2012. <a href="https://doi.org/10.4324/9780080942360">https://doi.org/10.4324/9780080942360</a></p> <p>- Ansoff, Henry. Strategic management. Springer, 2007.</p> <p>Periodicals</p> <p>- Marketing and Management of Innovations <a href="https://mmi.sumdu.edu.ua/ua/uammi/">https://mmi.sumdu.edu.ua/ua/uammi/</a></p> <p>- Інвестиційний менеджмент та фінансові інновації (Investment Management &amp; Financial Innovations) <a href="https://nfv.ukrintei.ua/">https://nfv.ukrintei.ua/</a></p> <p>- Наукові горизонти Scientific Horizons <a href="https://sciencehorizon.com.ua/uk">https://sciencehorizon.com.ua/uk</a></p> <p>Thematic databases</p> <p>- <a href="https://www.management.com.ua/">https://www.management.com.ua/</a></p> <p>- <a href="https://archive.doingbusiness.org/en/doingbusiness">https://archive.doingbusiness.org/en/doingbusiness</a></p> <p>- <a href="https://eba.com.ua/">https://eba.com.ua/</a></p> <p>Syllabi according to the study programme: <a href="https://web.kpi.kharkov.ua/mto/educational-programs/business-administration/">https://web.kpi.kharkov.ua/mto/educational-programs/business-administration/</a></p>
<b>9- Academic mobility</b>	
National Credit Mobility	Academic mobility is based on bilateral agreements between the National technical university “Kharkiv polytechnic institute” and other Ukrainian higher educational institutions
International Credit Mobility	The Programme is also conducted within the framework of the EU Erasmus+ program and provides for academic mobility on the basis of bilateral agreements between the National Technical University "Kharkiv Polytechnic Institute" and Lodz University of Technology (Lodz, Poland); Rhine-Waal University of Applied Sciences (Germany); Sapienza University (Rome, Italy), Istanbul Polytechnic University (Istanbul, Turkey).
Training of foreign applicants for higher education	According to the current legislation of Ukraine, it is possible to teach foreign citizens in English, provided that the previous educational level is recognized.

## 2. The list of components of the educational and professional programme Business Administration (In English)

Code	Components of the educational programme	Number of credits	Form of final assessment
1	2	3	4
<b>1.Obligatory components of EP</b>			
<i>1.1.General training</i>			
GT 1	Foreign Language	3,0	Differentiated grading, Exam
GT 2	Ukrainian language (professional)	16,0	Exam
GT 3	Higher Mathematics	6,0	Exam
GT 4	Jurisprudence	4,0	Exam
GT 5	History of Ukraine and Ukrainian culture	4,0	Differentiated grading
GT 6	Philosophy	3,0	Exam
GT 7	Fundamentals of artificial intelligence	4,0	Differentiated grading
GT 8	Microeconomics	5,0	Exam
GT 9	Macroeconomics	5,0	Exam
GT 10	Economic Statistics	4,0	Differentiated grading
GT 11	Fundamentals of Entrepreneurship	4,0	Exam
GT 12	Information technology in economic activity	5,0	Differentiated grading
GT	Physical education	4,0	Differentiated grading
<i>1.2.Professional training</i>			
PT 1	Introduction to Speciality (Introductory practice)	3,0	Differentiated grading
PT 2	Theory of Organization	5,0	
PT 3	Enterprise Economics	4,0	Exam
PT 4	Marketing	4,0	Exam
PT 5	Fundamentals of Management	8,0	Differentiated grading, Exam
PT 6	International Business	6,0	
PT 7	Managerial accounting	4,0	Differentiated grading
PT 8	Business planning	6,0	Exam
PT 9	Managerial decisions	4,0	Differentiated grading
PT 10	Finance of Enterprises	4,0	Differentiated grading
PT 11	Human Resource Management	5,0	Exam
PT 12	Riskology	4,0	Exam
PT 13	Fundamentals of business analysis	4,0	Exam
PT 14	Self-management	4,0	Exam
PT 15	Strategic Management	5,0	Exam
PT 16	Business communication	4,0	Exam
PT 17	Business modeling and projecting	6,0	Exam
<b>2.Practical training</b>			
PP1	Practical Training	6,0	Differentiated grading
PP2	Pre-graduation Practice	6,0	Differentiated grading
<b>3. Attestation</b>		<b>6,0</b>	

<b>Total amount for obligatory components</b>		<b>177</b>	
<b>4 Elective educational components</b>			
<b>4.1 Educational components of free choice of professional training of the general institute catalogue</b>			
EC PT	Elective educational components of professional training 1-12	48	Differentiated grading
<b>4.2 Educational components of the free choice of the university-wide catalogue</b>			
ECUC	Elective educational components 1-3	12	Differentiated grading
<b>4.2 Educational components of special university choice</b>			
ECSUC	Educational components of special university choice	3	Differentiated grading
<b>Total amount for elective components</b>		<b>63</b>	
<b>TOTAL AMOUNT FOR THE EDUCATIONAL PROGRAMME</b>		<b>240</b>	

### **3. ALLOCATION OF THE CONTENT OF THE EDUCATIONAL PROGRAMME AMONG GROUPS OF COMPONENTS AND TRAINING CYCLES**

№	Training cycle	Academic load on applicants for higher education (credits / %)		
		Obligatory components of the educational and professional programme	Optional components of the educational and professional programme	Total number for the entire period of study
1	2	3	4	5
1	General training cycle	67/28	15/6	82/34
2	Professional and practical training cycle	110/46	48/20	158/66
Total number for the entire period of study		177/74	63/26	240/100

#### **4. FORM OF CERTIFICATION OF APPLICANTS FOR HIGHER EDUCATION**

Attestation of graduates of the educational programme of the specialty D3 "Management" is carried out in the form of a public defense of the qualification thesis and is completed by issuing a document of the established sample on awarding him/her a bachelor's degree with the assignment of the qualification: bachelor of management.

The qualification thesis involves solving a complex specialized task or practical problem in the field of management, characterized by complexity and uncertainty of conditions, with the application of theories and methods of economic science.

The qualification thesis is checked for academic plagiarism, which includes automated checking using software tools and analysis of works by specialists in the relevant subject area, taking into account the results of such a check. The results of the check are displayed in the form established by the department.

The qualification thesis must be published in the university repository.

The publication of qualification theses containing information with limited access is carried out in accordance with the requirements of the law.

The public defense of the qualification thesis is held at an open meeting of the attestation commission.

## 5. REQUIREMENTS FOR THE INTERNAL QUALITY ASSURANCE SYSTEM FOR THE EDUCATIONAL PROGRAMME

Determined in accordance with the European Standards and Recommendations for Quality Assurance in Higher Education (ESG) and Article 16 of the Law of Ukraine "On Higher Education".

<p><b>Policy on quality assurance in higher education</b></p>	<p>The main principles of internal quality assurance of education at NTU KhPI: responsibility; adequacy; autonomy; measurability; the presence of academic culture and openness.</p> <p>The main procedures for internal quality assurance of education are:</p> <ol style="list-style-type: none"> <li>1. Implementation of quality policy, regarding the solution of strategic goals and objectives of continuous quality improvement;</li> <li>2. Ensuring the publicity of information about educational programs, higher education degrees and qualifications;</li> <li>3. Ensuring compliance with academic integrity by University employees and higher education applicants;</li> <li>4. Preparation and conduct of monitoring and socio-psychological research to determine the needs of the labor market, the requirements of higher education stakeholders, the quality of educational services and satisfaction with the quality of educational activities and the quality of education;</li> <li>5. Involvement of stakeholders (higher education applicants, employers, representatives of the academic community, etc.) in decision-making in the areas of internal quality assurance;</li> <li>6. External assessment of the quality of NTU KhPI activities based on the results of participation in national and international rankings of higher education institutions, fulfillment of Licensing requirements;</li> <li>7. Participation in accreditation procedures and post-accreditation monitoring of educational programs of the University.</li> </ol> <p>Areas: development, approval, monitoring and periodic review of educational programs; ensuring advanced training of pedagogical, scientific and scientific-pedagogical employees; ensuring student-centered and practice-oriented training, teaching and assessment of higher education applicants; ensuring the availability of necessary resources for organizing the educational process; ensuring the availability of information systems for effective management of the educational process.</p> <p>Based on the results of the audit of the quality management system, the University received a Certificate for the quality management system for the provision of services in the field of higher education; scientific research and experimental development, which confirmed that the Quality Management System of NTU "KhPI" meets the requirements of DSTU ISO 9001:2015. <a href="https://blogs.kpi.kharkov.ua/v2/quality/dokumenty/systema-upravlinnya-yakistyu/">https://blogs.kpi.kharkov.ua/v2/quality/dokumenty/systema-upravlinnya-yakistyu/</a></p>
<p><b>Ensuring the quality of development, approval, monitoring, review and</b></p>	<p>Monitoring and periodic review of educational programs is carried out in accordance with the current regulatory documents at NTU KhPI annually.</p> <p>The review of educational programs is carried out based on the analysis of satisfaction of:</p> <ul style="list-style-type: none"> <li>- educational needs of higher education applicants, the possibility of building an individual learning trajectory, compliance with academic freedoms in the</li> </ul>

<p><b>updating of educational programs</b></p>	<p>educational process, satisfaction with the quality of the educational program, etc.;</p> <ul style="list-style-type: none"> <li>- employers: the quality of formation of general and professional competencies, relevant and social skills (soft skills);</li> <li>- other stakeholders.</li> </ul> <p>To review educational programs, the following are used: online surveys, analysis of regulatory documents, analysis of the situation in accordance with the requirements for the structure and content of the educational program, organization of the educational process under this program and the quality of educational service provision.</p> <p>The periodicity of review of educational programs is carried out:</p> <ul style="list-style-type: none"> <li>a) annually according to the results of monitoring;</li> <li>b) after completion of the educational program by higher education applicants, regarding the feasibility of its further existence;</li> <li>c) in case of changes in the legislative and regulatory framework;</li> <li>d) according to the results of accreditation (general results of previous accreditations by industry, specialty, department, institute, university).</li> </ul> <p><a href="https://blogs.kpi.kharkov.ua/v2/quality/yakist-osvity/akredytatsiya-2023-2024/akredytatsiya-2024-2025/">https://blogs.kpi.kharkov.ua/v2/quality/yakist-osvity/akredytatsiya-2023-2024/akredytatsiya-2024-2025/</a></p>
<p><b>Ensuring enrollment, achievement, recognition and certification of applicants</b></p>	<p>Assessment of higher education applicants is consistent, transparent and carried out in accordance with the procedures established at the University in accordance with regulatory acts.</p> <p>Annual assessment of education applicants is carried out in accordance with the forms of control determined by the educational program; the scale for assessing learning outcomes, which is reflected in the syllabi of educational components; accounting, analysis and comparison of learning outcomes. Assessment of higher education applicants is carried out on the basis of a 100-point cumulative point-rating system. A rating assessment system is used.</p>
<p><b>Ensuring the quality of Student-Centered Learning, Teaching and Assessment</b></p>	<p>The planning, distribution and provision of educational resources, and the provision of information and technical support take into account the needs of higher education students and the principles of student-centered learning.</p> <p>Internal quality assurance of higher education ensures that all necessary resources meet the learning objectives, are publicly available, and higher education students are informed about their availability.</p>
<p><b>Ensuring the quality of scientific and pedagogical staff</b></p>	<p>The annual rating assessment of the activities of scientific and pedagogical staff and departments of the University is carried out through the use of mechanisms for assessing and self-assessing the effectiveness of scientific and pedagogical activities, its focus on the priorities of the development of the national higher education system, the University's development strategy, and the personal professional development of scientific and pedagogical staff. The results of the rating assessment are summarized based on the results of the activities achieved during the academic year. The results of the annual assessment of scientific and pedagogical staff and departments are published at a meeting of the Quality Council and the Methodological Council of the University. The results of the annual assessment are posted on the official website of the University.</p>

<p><b>Resource provision of the educational process (learning resources and support for higher education applicants)</b></p>	<p>The higher education institution provides the educational process with the necessary and accessible resources (human, methodological, material, information, etc.) and provides appropriate support to higher education applicants.</p> <p>Organizational and methodological support for the independent work of higher education applicants consists in developing methodological, didactic, and instructional materials, providing the opportunity to form, consolidate, deepen, and systematize the knowledge and skills obtained during classroom lessons, and to carry out self-training and self-control when mastering the educational and professional (scientific) program.</p>
<p><b>Information support (information management)</b></p>	<p>In order to manage the educational process, an effective policy in the field of information management and a corresponding integrated information system for managing the educational process have been developed.</p> <p>This system provides for the automation of the main functions of managing the educational process, in particular: ensuring the conduct of the admission campaign, planning and organization of the educational process; access to educational resources; accounting and analysis of the success of higher education applicants; administration of the main and auxiliary processes for ensuring educational activities; personnel management, etc.</p>
<p><b>Publicity of information about educational programs, educational and scientific activities</b></p>	<p>Reliable, objective, relevant, timely and easily accessible information on the educational and professional (scientific) program is published on the website of NTU "KhPI", including programs for potential higher education applicants, graduates, other stakeholders and the public.</p> <p>Public information is information on educational activities in the specialty, including selection criteria for study; planned learning outcomes for this program; training, teaching and assessment procedures used, etc.</p>
<p><b>Ensuring academic integrity</b></p>	<p>Ensuring the prevention and detection of academic plagiarism in scientific works of University employees and higher education students is implemented through the policy, standards and procedures for observing academic integrity and is regulated by the following documents of NTU KhPI:</p> <ol style="list-style-type: none"> <li>1. Charter of the National Technical University "Kharkiv Polytechnic Institute";</li> <li>2. Code of Ethics of Academic Relations and Integrity of the National Technical University "Kharkiv Polytechnic Institute";</li> <li>3. Regulations on the system for preventing and detecting academic plagiarism in final qualification theses of higher education students of the National Technical University "Kharkiv Polytechnic Institute";</li> <li>4. Regulations on the repository "Electronic archive of the National Technical University "Kharkiv Polytechnic Institute";</li> </ol> <p>Regulations on the Electronic Repository of Qualification Final Theses of Higher Education Students at the National Technical University "Kharkiv Polytechnic Institute"</p>

### 3. STRUCTURAL-LOGICAL SCHEME OF THE EDUCATIONAL PROGRAMME

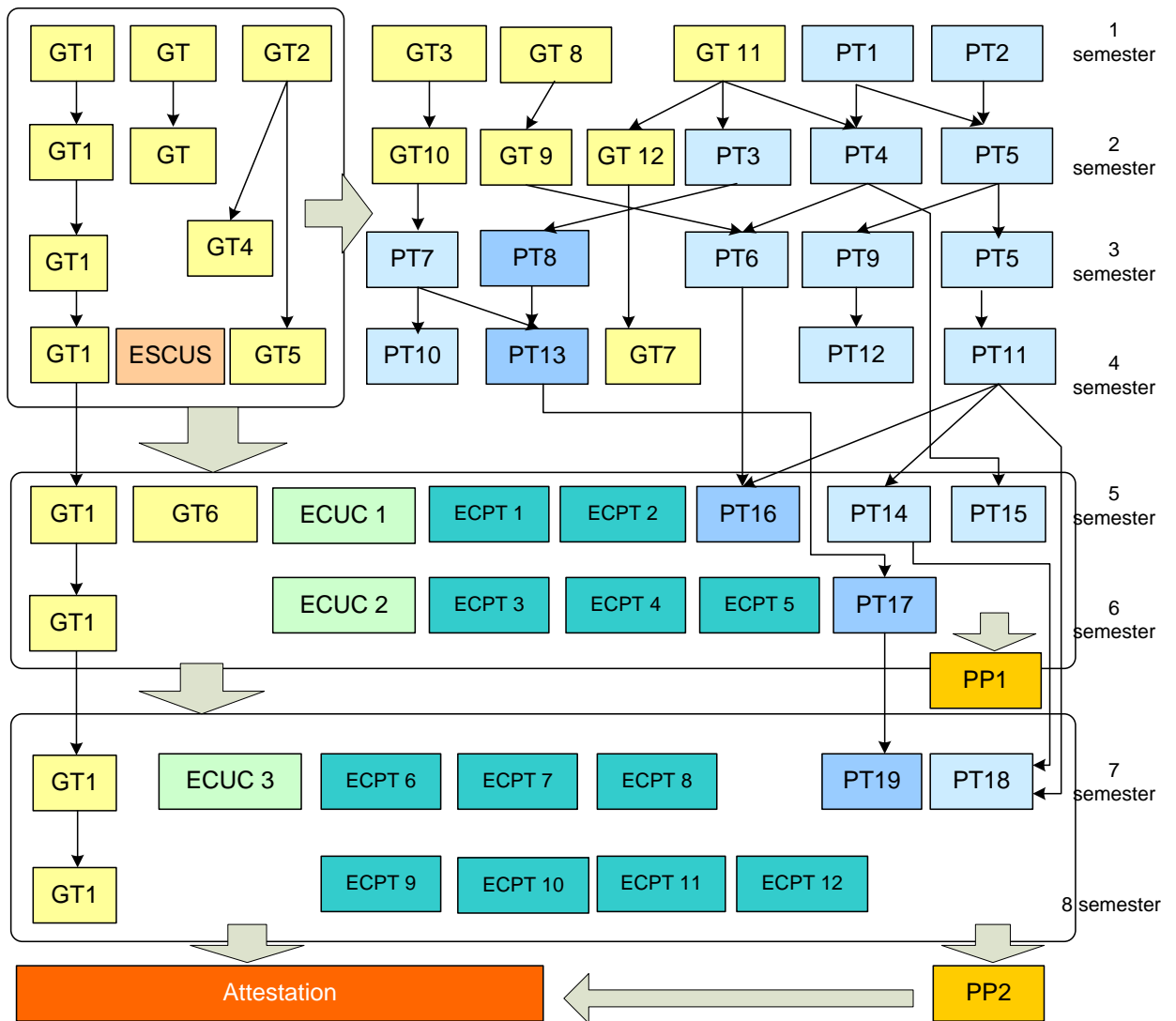

## 6.1 Matrix of correspondence between learning outcomes, general competencies and educational components

learning outcomes	competencies															
	Integral competency															
	general competencies															
	GC01	GC02	GC03	GC04	GC05	GC06	GC07	GC08	GC09	GC10	GC11	GC12	GC13	GC14	GC15	GC16
LO 1	GT5															
LO 2		GT5, GT														
LO 3				PT11, PT18, PP1	GT8, GT9 PT15, PT18			PT11	PT15							
LO 4				GT11, PT13, PT18, PP2							PT12, PT15	PT15, PT9				
LO 5																
LO 6								GT12, GT10, PT4, PT10	GT8, GT9, PT9							
LO 7																
LO 8													PT11, PT6			
LO 9																
LO 10											PT5					
LO 11			PT10, PT18					GT7, PT14, PP1, PP2								
LO 12															PT11, GT11, PT2	
LO 13						GT2, PT14	GT1, PT16							GT1, PT6, PT4		
LO 14															PT11	
LO 15												GT4, PT4				GT4, GT7
LO 16									GT6, GT7, PT2, PT3		GT11, PT5					
LO 17			GT3, GT10, PT7, PT10, PT18							GT3, PT11, PT13, PT15, PT8				PT6		
LO 18			PT12			PT16		PT16				PT12				

## 6.2 Matrix of correspondence between learning outcomes, professional competencies and educational components

learning outcomes	competencies																
	Integral competency																
	professional competencies																
	SC01	SC02	SC03	SC04	SC05	SC06	SC07	SC08	SC09	SC10	SC11	SC12	SC13	SC14	SC15	SC16	
LO 1						GT4											
LO 2																	
LO 3			PT15,PT18	PT15, PT18	PT11,PT15, PT18						PT5						
LO 4	PT10,PT14, PT18								PT11, PT13		PT10, PT12,PT9					PT17	
LO 5	PT2, PT5, PT3,PT18		PT2, PT15, PT18							PT5, PT11							
LO 6		PT7, PT4, PT5, PT12,PT13, PT19							GT10, PT5,		PT7, PT9, PT3, PT5, PT10,PT12					PT12	
LO 7	PT2	PT2, PT17	PT2, PT12, PT17	PT2, PT15, PT17												PT12	
LO 8	PT5, PT18	PT5, PT6, PT15,PT18			PT5, PT11	PT5	PT5, PT11, PT15,PT18				PT5, PT11						
LO 9					PT18			PT14					PT14		PT1, PT18	PT17	
LO 10				PT5, PT18													
LO 11											PT11,PT6,						
LO 12							PT11,PP2								PT11, PT16	GT11	PT19
LO 13											PT6, PT11, PT16					PT16	
LO 14													PT11			PT16	
LO 15							PT11,								PT11, PT16	GT11	
LO 16															PT14		
LO 17										PT1, PT11, PT14,							PT19
LO 18		PT12,PT19	PT12,PT17, PT19,PT8								PT8, PT12, PT17	PT16	PT19				